

SCB2675

Color/Monochrome Attributes Controller (CMAC)

Product Specification

Microprocessor Products

DESCRIPTION

The Signetics SCB2675 Color/Monochrome Attributes Controller (CMAC) is a bipolar LSI device designed for CRT terminals and display systems that employ raster scan techniques. It contains a programmable dot clock divider to generate a character clock; a high-speed shift register to serialize input dot data into a video stream; latches and logic to apply visual attributes to the resulting display; and logic to display a cursor on the display.

The CMAC provides control of visual attributes on a character-by-character basis for two operating modes: monochrome and color. The monochrome mode provides reverse video, blank, highlight and two general purpose user-definable attributes. In this mode, the display characters can be specified to appear on either a light or dark screen background. Retrace video suppression can be automatically or externally controlled. The color mode provides eight colors for foreground (character) video and eight colors for background video together with a luminance output for external color set selection, or to simultaneously drive a monochrome monitor. Additionally, both modes provide double width, underline, blink, dot stretching and dot width attributes. In monochrome mode, the SCB2675 emulates the attribute characteristics of Digital Equipment Corporation's VT100 terminal.

The horizontal dot frequency is the basic timing input to the CMAC. This clock is divided internally to provide a character clock output for system synchronization. Up to nine bits of dot data are parallel loaded into the video shift register on each character boundary. The two TTL video data outputs in monochrome mode are encoded to provide four video intensities (black, gray, white and highlight). The video data in color mode is encoded to provide eight foreground colors and shifted out on three TTL outputs, together with the luminance output.

FEATURES

- 25MHz and 18MHz video dot rate versions*
- Four video intensities encoded on two TTL outputs (monochrome mode)
- Eight foreground and background colors encoded on three TTL outputs (color mode)
- Internally latched character attributes:
 - Reverse video
 - Blank
 - Blink
 - Underline
 - Highlight
 - Two general purpose
 - Eight foreground colors
 - Eight background colors
 - Dot width control
 - Double width characters
- VT100 compatible attributes
- Reverse video cursor with optional white cursor in color mode
- Up to 10 dots per character
- Light or dark background in monochrome mode
 - Automatic retrace blanking
- Programmable dot stretching
- Compatible with SCN2674 AVDC and SCN2670 DCGG
- TTL compatible
- 40-pin dual-in-line package

APPLICATIONS

- CRT terminals
- Word processing systems
- Small business computers

*40MHz SCB2675T also available.

PIN CONFIGURATIONS

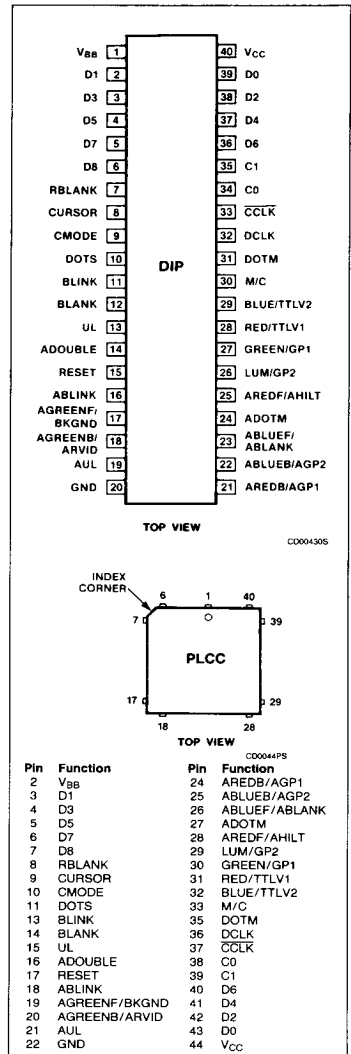

Color/Monochrome Attributes Controller (CMAC)

SCB2675

ORDERING INFORMATION

PACKAGES	DOTS PER CHARACTER	V _{CC} = +5V ± 5%, 0°C to +70°C	
		25MHz	18MHz
Ceramic DIP Plastic DIP Plastic LCC	7, 8, 9, 10	SCB2675BC5I40 SCB2675BC5N40 SCB2675BC5A44	SCB2675BC8I40 SCB2675BC8N40 SCB2675BC8A44
Ceramic DIP Plastic DIP Plastic LCC	6, 8, 9, 10	SCB2675CC5I40 SCB2675CC5N40 SCB2675CC5A44	SCB2675CC8I40 SCB2675CC8N40 SCB2675CC8A44

BLOCK DIAGRAM

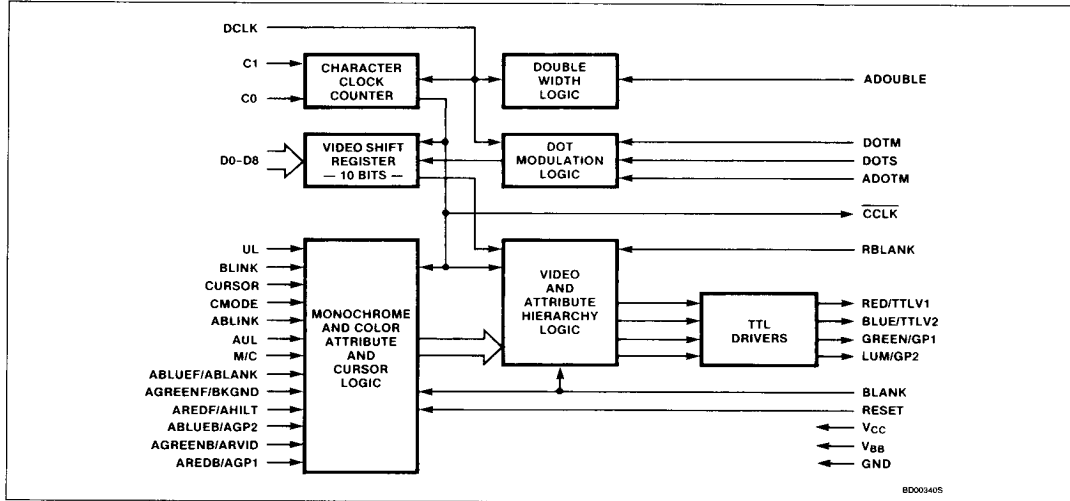

Color/Monochrome Attributes Controller (CMAC)

SCB2675

PIN DESCRIPTION

MNEMONIC	PIN NO.		TYPE	NAME AND FUNCTION
	DIP	PLCC		
V _{CC}	40	44	I	Power supply: +5V ± 5%
V _{BB}	1	2	I	Bias Supply: See Figure 5
GND	20	22	I	Ground: 0V reference
DCLK	32	36	I	Dot Clock: Dot frequency input. Video output shift rate.
CCLK	33	37	O	Character Clock: An output which is a submultiple of DCLK. The period ranges from 6 to 10 DCLK periods per cycle and is determined by the state of the C0, C1 inputs.
RED/TTLV1	28	31	O	Red/TTL Video 1: In color mode, this output provides the red gun serial video. In monochrome mode, it should be used with the blue/TTL video 2 output to decode four video intensities.
BLUE/TTLV2	29	32	O	Blue/TTL Video 2: In color mode, this output provides the blue gun serial mode. In monochrome mode, it should be used with the red/TTL video 1 output to decode four video intensities.
GREEN/GP1	27	30	O	Green/General Purpose 1: In color mode, this output provides the green gun serial video. In monochrome mode, it is a general purpose TTL output which is asserted if the AREDB/AGP1 input is asserted when the corresponding character dot data is loaded into the video shift register. GP1 can be active in either active scan or blank time.
LUM/GP2	26	29	O	Luminance/General Purpose 2: In color mode, this output is the logical-OR of the RGB foreground video. It is low during a blanking interval and during the foreground portion of the cursor display. In monochrome mode, it is a general purpose TTL output which is asserted if the ABLUEB/AGP2 input is asserted when the corresponding character dot data is loaded into the video shift register. GP2 can be active in either active scan or blank time.
UL	13	15	I	Underline Timing: Indicates the scan line(s) for the underline attribute. Latched on the falling edge of BLANK. The underline will be displayed on the specified scan line for every character where AUL = 1.
BLINK	11	13	I	Blink Timing: This input is sampled on the falling edge of BLANK to provide the blink rate for the blink attribute. Should be a submultiple of the frame rate.
BLANK	12	14	I	Screen Blank: When high, this input forces the video outputs to the specified background color in color mode and to the level specified by the BKGND input (either black or gray) in monochrome mode.
RBLANK	7	8	I	Retrace Blank: This input is used to force the video outputs to a low during retrace periods. If pulled high, it will automatically suppress video during the retrace periods when BLANK is high. The user may also pulse this input while BLANK is high to selectively suppress raster video.
AGREENF/BKGND	17	19	I	Green Foreground/Background Intensity: In color mode, this input activates the GREEN/GP1 output during the foreground (character video) portion of the associated character block. In monochrome mode, this input specifies gray or black screen background.
ABLUEF/ABLANK	23	26	I	Blue Foreground/Blank Attribute: In color mode, this input activates the BLUE/TTLV2 output during the foreground (character video) portion of the associated character block. In monochrome mode, this input generates a blank space for the associated character. The blank space intensity is controlled by the AGREENF/BKGND input, the reverse video attribute and cursor input.
AREDF/AHILT	25	28	I	Red Foreground/Highlight Attribute: In color mode, this input activates the RED/TTLV1 output during the foreground (character video) portion of the associated character block. In monochrome mode, this input highlights the associated character (including underline).
CURSOR	8	9	I	Cursor Timing: This input provides the timing for the cursor video. In color mode, with CURSOR and CMODE high, the RGB outputs are driven high (white cursor). If CMODE is low, or in monochrome mode, this input reverses the intensities of the video and attributes (the foreground and background intensities are reversed). Cursor position, shape, and blink rate are controlled by this input.
CMODE	9	10	I	Cursor Mode: Used in color mode only. When CURSOR and CMODE are high, the RGB outputs are driven high (white cursor). When CURSOR is high and CMODE is low, the RGB outputs are logically inverted (reverse video cursor).
AUL	19	21	I	Underline Attribute: Specifies a line to be displayed in the character block. The specific line(s) are specified by the UL input. All other attributes apply to the underline video.
ABLANK	16	18	I	Blink Attribute: In color mode, this active high input will drive the foreground RGB combination to the background RGB combination. In monochrome mode, the associated character or background is driven to the intensity determined by BKGND, reverse video attribute and the cursor input.

Color/Monochrome Attributes Controller (CMAC)

SCB2675

PIN DESCRIPTION (Continued)

MNEMONIC	PIN NO.		TYPE	NAME AND FUNCTION
	DIP	PLCC		
ADDOUBLE	14	16	I	Double Width Attribute: This active high input causes the associated character video to be shifted out of the serial shift register at one half the dot frequency (DCLK). The CCLK output is not affected.
AREDB/ AGP1	21	24	I	Red Background/General Purpose Attribute 1: In color mode, this input activates the RED/TTLV1 output during the background portion of the associated character block. In monochrome mode, it activates the GREEN/GP1 output for the associated character block.
ABLUEB/ AGP2	22	25	I	Blue Background/General Purpose Attribute 2: In color mode, this input activates the BLUE/TTLV2 output during the background portion of the associated character block. In monochrome mode, it activates the LUM/GP2 output for the associated character block.
AGREENB/ ARVID	18	20	I	Green Background/Reverse Video Attribute: In color mode, this input activates the GREEN/GP1 output during the background portion of the associated character block. In monochrome mode, it causes the associated character block video intensities to be reversed.
D0 - D8	39, 2, 38, 3, 37, 4, 36, 5, 6	43, 3, 42, 4, 41, 5, 40, 6, 7	I	Dot Data Input: These are parallel inputs corresponding to the character/graphic symbol dot data for a given scan line. These inputs are strobed into the video shift register on the trailing (falling) edge of each character clock (CCLK).
C0, C1	34, 35	38, 39	I	Character Clock Control: The states of these two static inputs determine the internal divide factor for the CCLK output rate.
RESET	15	17	I	Reset: This active high input initializes the internal logic and resets the attribute latches.
M/C	30	33	I	Monochrome/Color Mode: This input selects whether the CMAC operates in monochrome or color mode. A low selects color mode and a high selects monochrome mode.
ADOTM	24	27	I	Dot Modulation Attribute: When DOTM and this input are high, the active dot width of the associated character video is one DCLK. When DOTM is high and this input is low, the active dot width of the associated character video is two DCLKs.
DOTM	31	35	I	Dot Width Modulation: When this input is high, two DCLKs are used for each dot shifted through the shift register. When this input is low, one DCLK is used.
DOTS	10	11	I	Dot Stretching: Sampled at the falling edge of BLANK. When this input is high, one extra dot is appended to individual dots or groups of dots of the input parallel data and then transferred through the shift register. When this input is low, normal transfer of input parallel data results.

FUNCTIONAL DESCRIPTION

The CMAC consists of seven major sections (see block diagram). The high-speed dot clock input is applied to a programmable divider to provide a character clock output for system timing. Parallel dot data is loaded into the video shift register on character boundaries and shifted into the video logic block at the dot rate specified by the dot modulation section. The appropriate attribute control inputs are selected by the mode select logic, latched internally on character boundaries, and combined with the serial dot data to provide monochrome or color video outputs.

The BLANK input defines the active screen and retrace areas. In color mode, the video outputs are forced to the specified background color when this signal is asserted; in monochrome mode the video outputs are forced to the states defined by the BKGND input, i.e., black if dark background is selected and gray if light background is selected. A separate RBLANK input allows the user to select the amount of border around the active area when operating in color mode or in monochrome mode with light background.

Table 1. Monochrome Mode Attribute Characteristics

REV ¹	AHILT	ABLANK ²	BACKGROUND VIDEO	BACKGROUND VIDEO
0	0	0	W	B
0	0	1	W/G	B
0	1	0	H	B
0	1	1	H/W	B
1	0	0	B	G
1	0	1	B/W	G/B
1	1	0	B	W
1	1	1	B/H	W/B

NOTES:

- REV = (BKGND) XOR (ARVID):

BKGND	ARVID	REV
0	0	0
0	1	1
1	0	1
1	1	0
- For blinking, the video outputs are shown as 0/1, where 0 and 1 are the blink timing input states.
- Foreground includes underline when underlining is specified by AUL = 1.
- When ABLANK = 1, foreground component becomes same as background component.
- Codes for video outputs are as follows:

CODE	TTLV2	TTLV1	BEAM INTENSITY
B	0	0	Black (B)
G	0	1	Gray (G)
W	1	0	White (W)
H	1	1	Highlight (H)

Color/Monochrome Attributes Controller (CMAC)

SCB2675

This input can be tied high, in which case the area outside the active area will be dark, or it may be pulsed during BLANK periods to externally control the border widths.

In color mode, eight colors for the character (foreground) and eight colors for the background (area other than character) can be selected by the attribute inputs. In monochrome mode, the intensities of foreground and background are a function of the attribute and BKGND inputs, i.e., characters may be black, gray, white, or highlight (very white) while background may be black, gray, or white (see Table 1).

Character Clock Counter

The character clock counter divides the DCLK input to generate the character clock (CCLK). The divide factor is specified by the clock control inputs (C1, C0) as follows:

C1	C0	SCB2675B	
		Dots/Char.	CCLK Duty Cycle*
0	0	10	5/5
0	1	7	3/4
1	0	8	4/4
1	1	9	4/5

NOTE:
*High/Low

C1	C0	SCB2675C	
		Dots/Char.	CCLK Duty Cycle*
0	0	10	5/5
0	1	6	3/3
1	0	8	4/4
1	1	9	4/5

NOTE:
*High/Low

The number of dot clocks/character is normally the number of dots/character as listed above. However, when dot width control is specified, the DCLK input is divided by two before it is applied to the character clock counter resulting in the number of dot clocks/character being double those listed above, although the number of displayed dots/character remains the same. The number of dots per character (C1, C0) can be dynamically changed on either edge of the character clock as shown in Figure 10 (See Dot Modulation Logic).

Video Shift Register

On each character boundary, the parallel input dot data (D0 - D8) is loaded into the video shift register. The data is shifted out least significant bit first (D0) at the DCLK rate. If 10 dots/character are specified (C1, C0 = 00), the tenth dot will be the same as

D8. The serial dot data from the video shift register is routed to the video logic where it is combined with the cursor and attribute control bits to produce the video data outputs.

Mode Select, Attribute And Cursor Control

The mode select logic multiplexes the monochrome and color attribute inputs and outputs as specified by the M/C input. The monochrome mode provides blank, reverse video, highlight and two general purpose attributes. The latter may be used, with external logic, to combine other attributes (e.g., overscore) into the video stream. The color mode provides RGB foreground and background color attributes. Both modes provide double width characters, blink, underline, dot width control and dot stretching.

The cursor and attribute inputs are pipelined internally to allow for system pipeline propagations. The cursor input and the attribute inputs are delayed for one CCLK to account for the delay of the character data through the character generator latches. The attribute timing inputs (BLINK, UL and DOTS) are clocked into the 2675 at the beginning of each scan line time by the falling edge of BLANK. Thus, these inputs must be in their proper state at the falling edge of BLANK preceding the scan line where they are required to be active. The BLANK signal itself is also delayed internally to provide for the RAM and character generator delays (see Figures 6 and 7). Internal delays cause the video outputs to be delayed relative to CCLK as illustrated in Figure 8.

Video Logic

Each character block consists of the three components shown in Figure 1. Symbol video is generated from the dot data inputs D0 - D8. Underline video is enabled by the AUL attribute and is generated during the scan lines for which the UL input is active. Underline and symbol video are always the same intensity or color, and other attributes (e.g., ABLINK) apply to them equally. The combination of underline and symbol video is also referred to as foreground video. Background video is the area of the character block corresponding to the absence of foreground video. The assertion of the non-display attribute in the monochrome mode (ABLANK) causes the entire character block to be displayed as background.

In monochrome mode, the serial dot data and pipelined cursor and attributes are combined to generate four video intensities (black, gray, white and highlight) which are encoded on the TTLV1 and TTLV2 outputs as follows:

TTLV2	TTLV1	VIDEO INTENSITY
0	0	Black
0	1	Gray
1	0	White
1	1	Highlight

Table 1 describes the relationship between attributes and video intensity of the foreground and background components of the character block in monochrome mode.

In color mode, the colors of the foreground and background components are specified by the corresponding attribute inputs; AREDF, AGREENF and ABLUEF dictate the color of the foreground component while AREDB, AGREENB and ABLUEB do the same for the background component. In this mode, the serial dot data and pipelined cursor and attributes are combined to generate four video outputs. The RED, GREEN and BLUE outputs separately contain the corresponding foreground and background components. The LUM output is the logical-OR of the foreground colors and can be used to drive a separate monochrome monitor or to select a different set of colors for the foreground.

Dot Modulation Logic

The dot modulation logic controls the video shift register to supply dot stretching and dot width control.

Dot stretching is controlled by the DOTS input which is sampled by each scan line at the trailing (falling) edge of BLANK. If DOTS is asserted at that time, all characters on the following scan line will have dot stretching applied. Dot stretching causes an extra dot to be added to individual dots or groups of dots as shown in Figures 2 and 3. Dot stretching also can be used to:

1. Compensate for low video bandwidth monitors (since the minimum active displayed segment with dot stretching is two DCLKs).
2. Assure crisp black characters when operating in white background mode.
3. Provide thick characters as a means of distinguishing areas of the display.

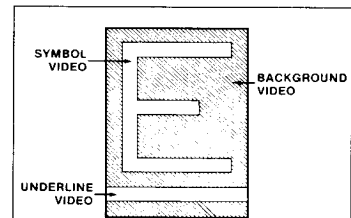

Figure 1. Character Block Definition

2

Color/Monochrome Attributes Controller (CMAC)

SCB2675

Dot width is controlled by the DOTM and ADOTM inputs. DOTM is tied either high, which enables the feature on the entire display, or low, which disables the feature. With ADOTM high, the dot width of characters can be selectively controlled by assertion of the ADOTM attribute input. When operating in this mode, the dot clock input is divided by two before being applied to other circuits in the CMAC. The \overline{CCLK} output is also divided by two.

The truth table for the possible combinations of ADOTM and DOTM is as follows:

ADOTM	DOTM	OPERATION
0	0	Normal mode
0	1	Dot width control, 100% duty cycle (DCLK ÷ 2, CCLK ÷ 2)
1	0	Not allowed
1	1	Dot width control, 50% duty cycle (DCLK ÷ 2, CCLK ÷ 2)

When dot width control is enabled as above, two DCLKs are used for each video dot period. Asserting ADOTM for a particular character will cause each active video dot of the displayed character to be turned on for one DCLK and off for the other DCLK, while if ADOTM is negated for that character, the active video dot for that character will be turned on (black background) or off (white background) for both DCLK times (see Figures 2 and 4). Only the character video component of the character block is modulated. Underline video and background are not affected by ontime modulation. Width control can be used to:

1. Make horizontal lines and vertical lines appear the same brightness on the display.
2. Provide two different brightness levels for characters without requiring a monitor with analog brightness inputs.

However, note that the effects produced by this feature are highly dependent on the video amplifier characteristics of the monitor used.

Double Width Logic

The double width logic controls the rate at which dots are shifted through the video shift register. When the ADOUBLE input is asserted, the associated character video will be shifted at one half the DCLK rate, and the dot information for the next character will be loaded into the shift register two \overline{CCLK} s later. The character and attribute data that is present on the first \overline{CCLK} after the ADOUBLE input is asserted will be ignored. The \overline{CCLK} output is not affected. If a double width character is specified at the last location of a character row, the second half of the double width character (one \overline{CCLK}) will extend into the horizontal front porch.

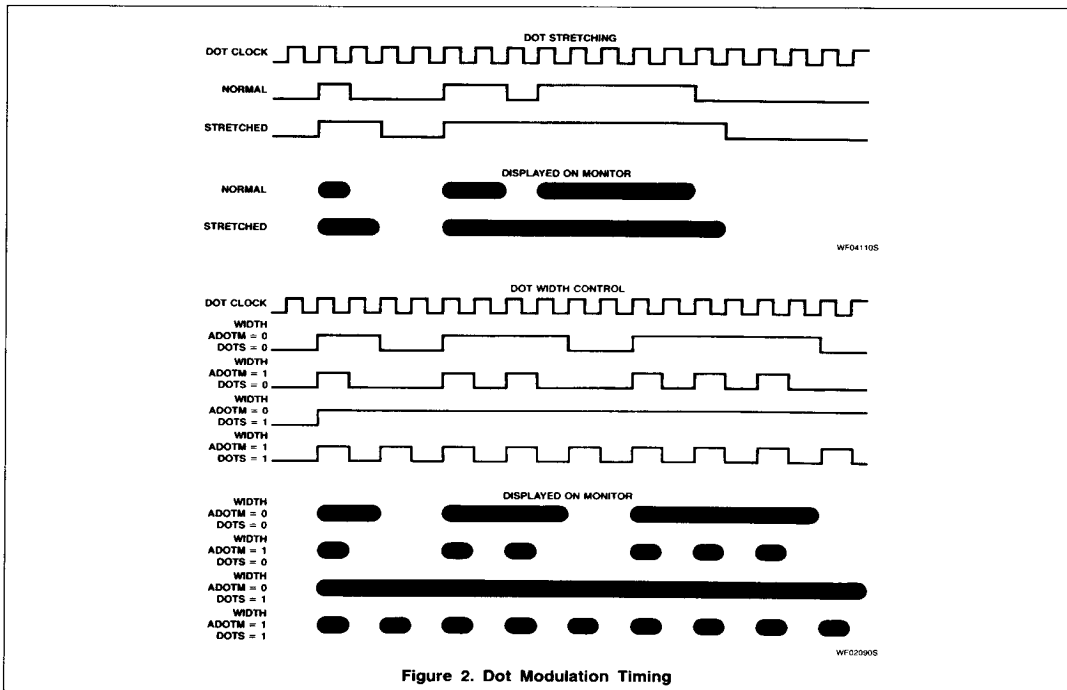
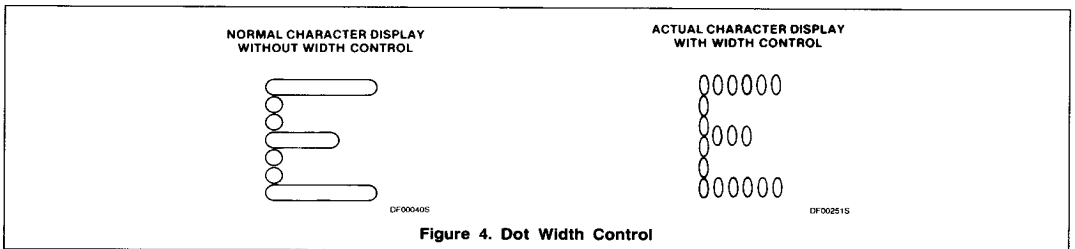
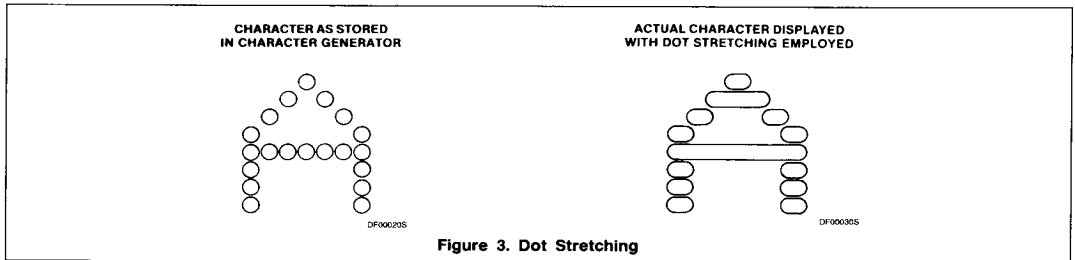

Figure 2. Dot Modulation Timing

Color/Monochrome Attributes Controller (CMAC)

SCB2675



ABSOLUTE MAXIMUM RATINGS¹

SYMBOL	PARAMETER	RATING	UNIT
T _A	Operating ambient temperature ² range	0 to +70	°C
T _{STG}	Storage temperature range	-65 to +150	°C
	All voltages with respect to ground ³	-0.5 to +6.0	V

DC ELECTRICAL CHARACTERISTICS T_A = 0°C to +70°C, V_{CC} = +5V ± 5%, V_{BB} = Figure 5^{4, 5}

SYMBOL	PARAMETER	TEST CONDITIONS	LIMITS			UNIT
			Min	Typ	Max	
V _{IL}	Input low voltage	I _{OL} = 4mA I _{OH} = -400μA	2		0.8	V
V _{IH}	Input high voltage					V
V _{OL}	Output low voltage					V
V _{OH}	Output high voltage					V
I _{IL}	Input low current DCLK All other inputs	V _{IN} = 0.4V			-800	μA
I _{IH}	Input high current DCLK All other inputs	V _{IN} = 2.4V			-400	μA
I _{CC}	V _{CC} supply current	V _{IN} = 0V, V _{CC} = Max Figure 5			80	mA
I _{BB}	V _{BB} supply current					120

Color/Monochrome Attributes Controller (CMAC)

SCB2675

AC ELECTRICAL CHARACTERISTICS $T_A = 0^\circ\text{C}$ to $+70^\circ\text{C}$, $V_{CC} = +5V \pm 5\%$, $V_{BB} = \text{Figure 5}^{4, 5}$

SYMBOL	PARAMETER	TEST CONDITIONS	LIMITS				UNIT
			25MHz Version		18MHz Version		
			Min	Max	Min	Max	
Dot clock timing (see Figure 8)							
f_D	Frequency			25		18	MHz
t_{DH}	High time		15		22		ns
t_{DL}	Low time		15		22		ns
Setup times (see Figures 6, 7, 9, and 10)							
t_{SB}	BLANK to \overline{CCLK}		40		50		ns
t_{SA}	Attributes to \overline{CCLK}		40		50		ns
t_{SD}	D0 - D9 to \overline{CCLK}		70		70		ns
t_{SK}	CURSOR to \overline{CCLK}		40		50		ns
t_{SC}	C0, C1 to DCLK		30		35		ns
t_{SR}	RBLANK to DCLK		20		20		ns
t_{SM}	BLINK, UL, DOTS to BLANK		20		20		ns
Hold times (see Figures 6, 7, 9, and 10)							
t_{HB}	BLANK from \overline{CCLK}		20		20		ns
t_{HA}	Attributes from \overline{CCLK}		20		20		ns
t_{HD}	D0 - D8 from \overline{CCLK}		30		30		ns
t_{HK}	CURSOR from \overline{CCLK}		20		20		ns
t_{HC}	C0, C1 from DCLK		20		20		ns
t_{HR}	RBLANK from DCLK		20		20		ns
t_{HM}	BLINK, UL, DOTS from BLANK		20		20		ns
Delay times (see Figure 8)							
t_{DC}	\overline{CCLK} from DCLK	$C_L = 50\text{pF}$		55		70	ns
t_{DV}	Other outputs from DCLK			60		70	ns

NOTES:

1. Stresses above those listed under Absolute Maximum Ratings may cause permanent damage to the device. This is a stress rating only and functional operation of the device at these or at any conditions other than those described in the AC and DC Electrical Characteristics section of this specification is not implied.
2. For operating at elevated temperatures, the device must be derated based on $+150^\circ\text{C}$ maximum junction temperature.
3. This product includes circuitry specifically designed for the protection of its internal devices from damaging effects of excessive static charge. Nonetheless, it is suggested that conventional precautions be taken to avoid applying voltages greater than the rated maxima.
4. Parameters are valid over operating temperature range unless otherwise specified.
5. All voltage measurements are referenced to ground. For testing, all input signals swing between 0.4V and 2.4V with a transition time of 3ns maximum and output voltages are checked at 0.8V and 2V.

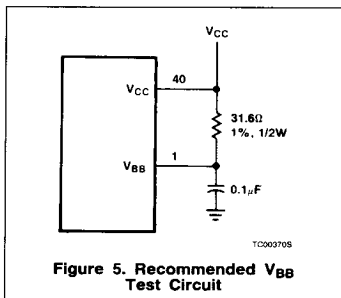

Color/Monochrome Attributes Controller (CMAC)

SCB2675

2

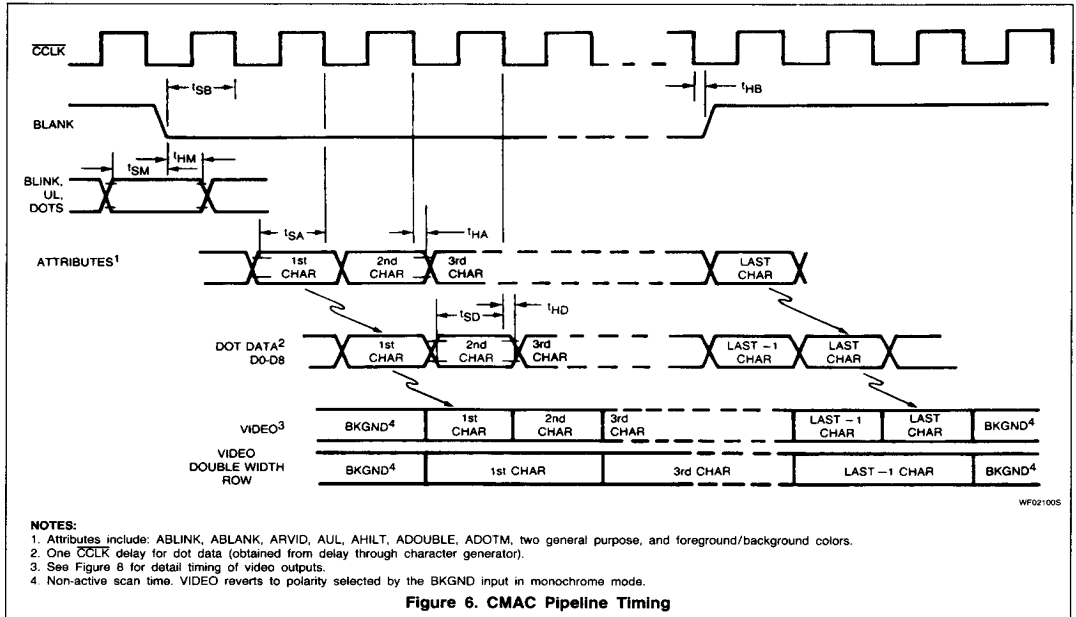

Figure 6. CMAC Pipeline Timing

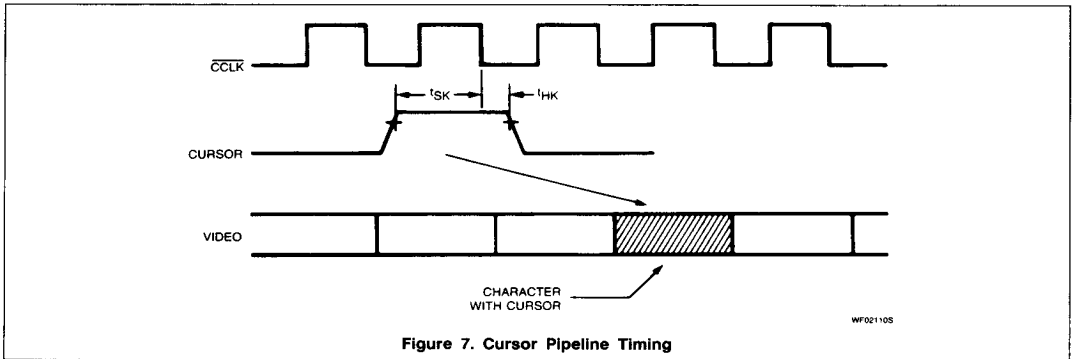
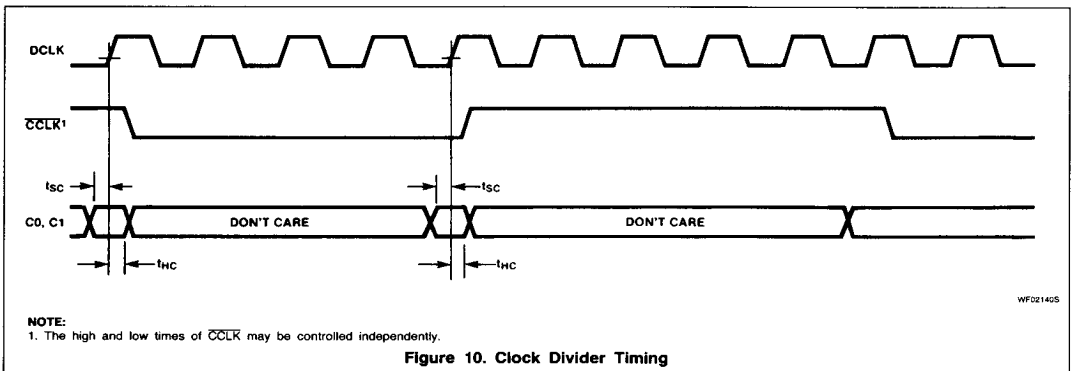
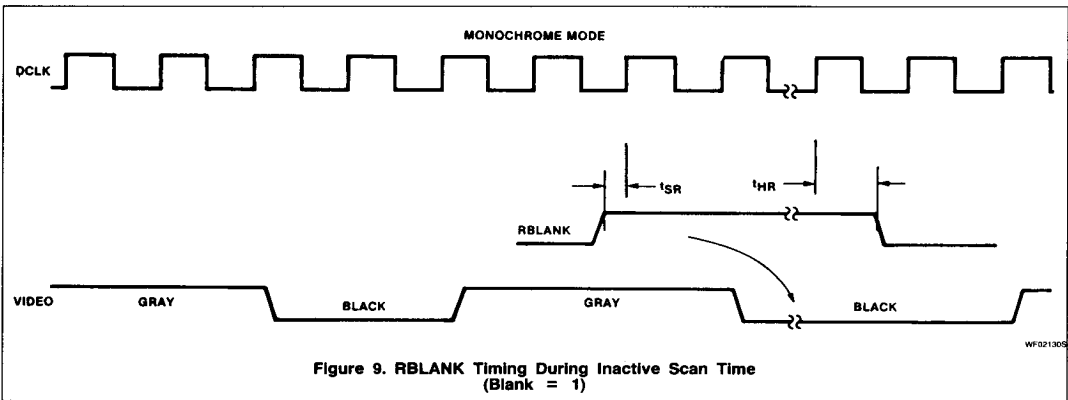
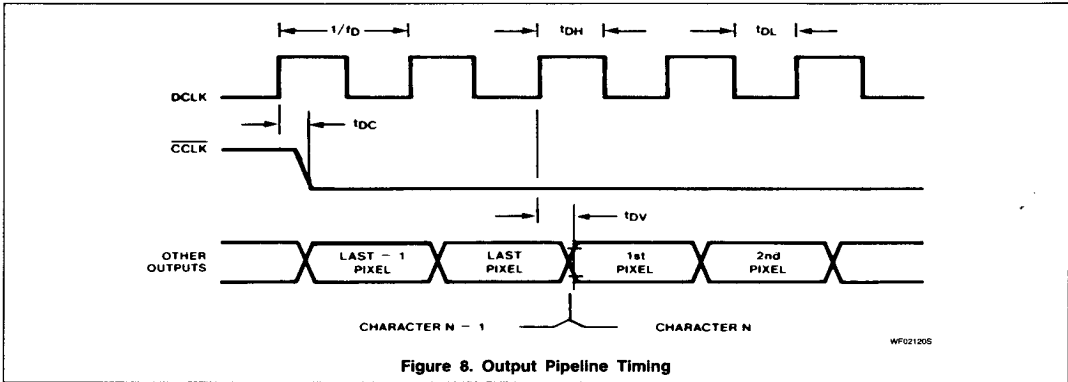

Figure 7. Cursor Pipeline Timing

Color/Monochrome Attributes Controller (CMAC)

SCB2675



Color/Monochrome Attributes Controller (CMAC)

SCB2675

2

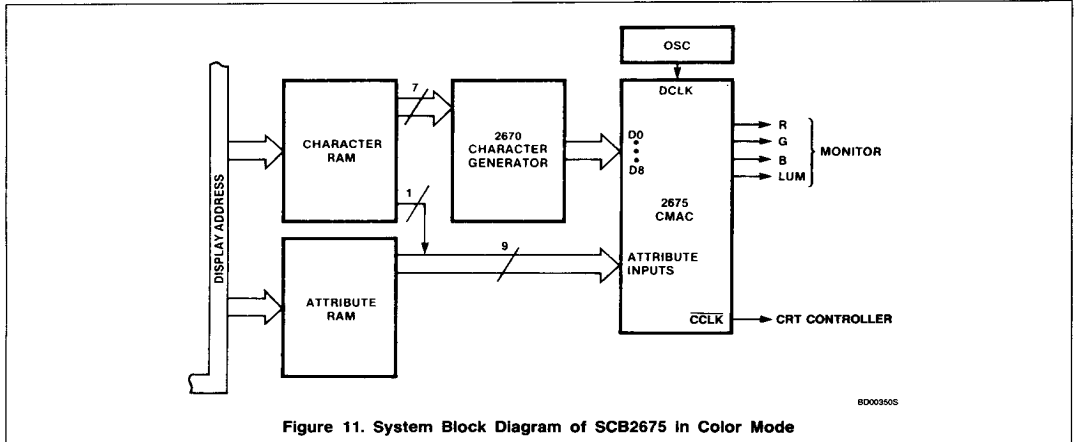

Figure 11. System Block Diagram of SCB2675 in Color Mode

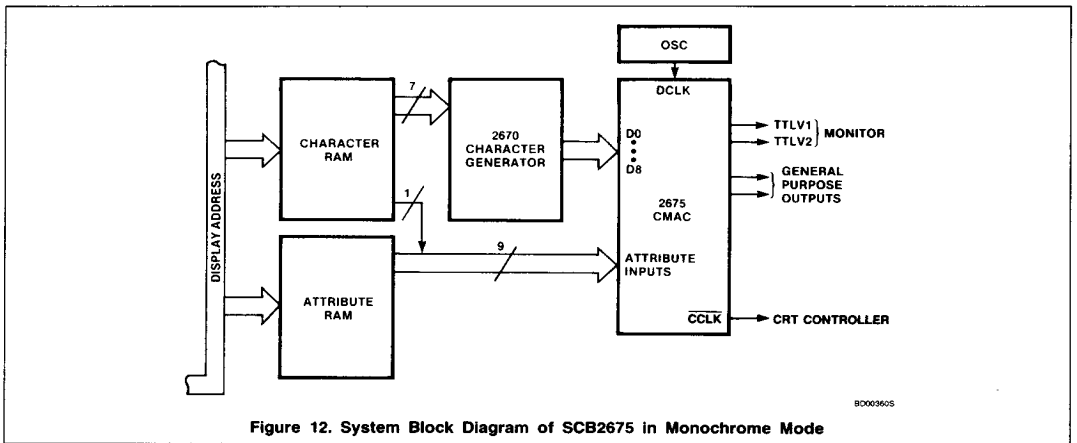

Figure 12. System Block Diagram of SCB2675 in Monochrome Mode